

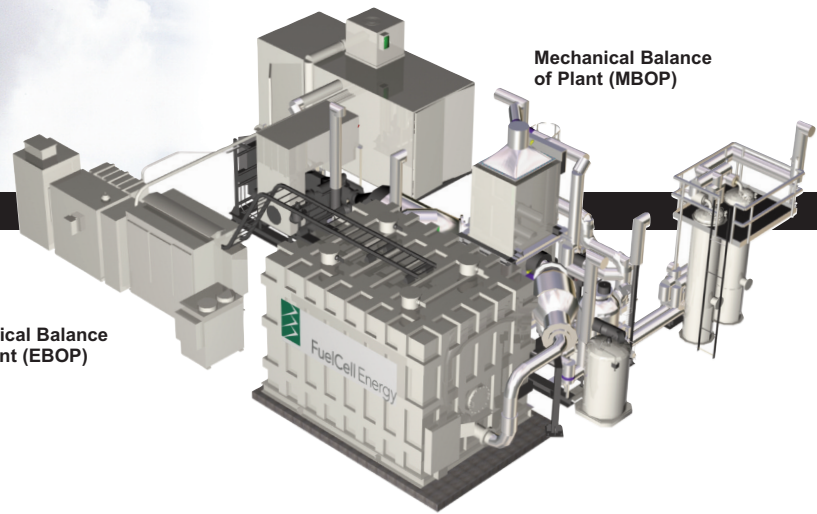

FuelCell Energy

Ultra-Clean, Efficient, Reliable Power

DFC1500



Key Features

- High Efficiency
- Low Environmental Impact
- Fuel Flexibility
- High Reliability
- Quiet Operation

Advantages

The DFC1500™ stationary fuel cell power plant from FuelCell Energy provides high-quality, Ultra-Clean electrical power with 47% efficiency around-the-clock. Designed for commercial and industrial applications, the system offers easy transport, quiet and reliable operation, and easy site planning and regulatory approval. The DFC1500 is ideal for wastewater treatment plants, manufacturing, food and beverage processing, universities and office campuses.

Performance

Power Output

Power @ Plant Rating	1,400 kW
Standard Output AC Voltage	480 V
Standard Frequency	60 Hz
Optional Output AC Voltages	By Request
Optional Output Frequency	50 Hz

Efficiency

LHV	47 +/- 2 %
-----	------------

Available Heat

Exhaust Temperature	700 +/- 50 °F
Exhaust Flow	18,300 lb/h
Allowable Backpressure	5 iwc
Heat Energy Available for Recovery (to 250°F)	2,216,000 Btu/h
(to 120°F)	3,730,000 Btu/h

Fuel Consumption

Natural gas (at 930 Btu/ft ³)	181 scfm
Heat rate, LHV	7,260 Btu/kWh

Water Consumption

Average	4.5 gpm
Peak during WTS backflush	15 gpm

Water Discharge

Average	2.25 gpm
Peak during WTS backflush	15 gpm

Pollutant Emissions

NOx	0.01 lb/MWh
SOx	0.0001 lb/MWh
PM10	0.00002 lb/MWh

Greenhouse Gas Emissions

CO ₂	980 lb/MWh
CO ₂ (with waste heat recovery)	520-680 lb/MWh

Sound Level

Standard	72 dB(A) at 10 feet
----------	---------------------

**1.4 MW, 480 VAC,
1,550 kVA, 50 or 60 Hz**

Specifications

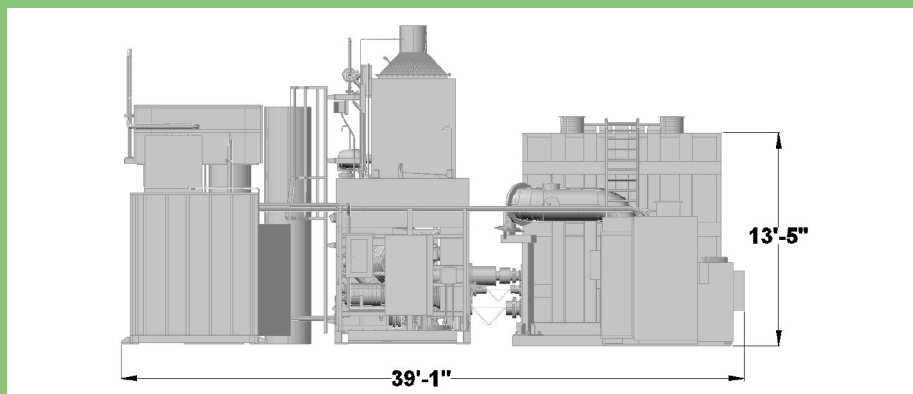

Weights

Water Treatment Skid
20,000 lb

Main Process Skid
50,000 lb

Desulfurization
15,000 lb

Electrical Balance of Plant
26,500 lb

Fuel Cell Module
107,000 lb

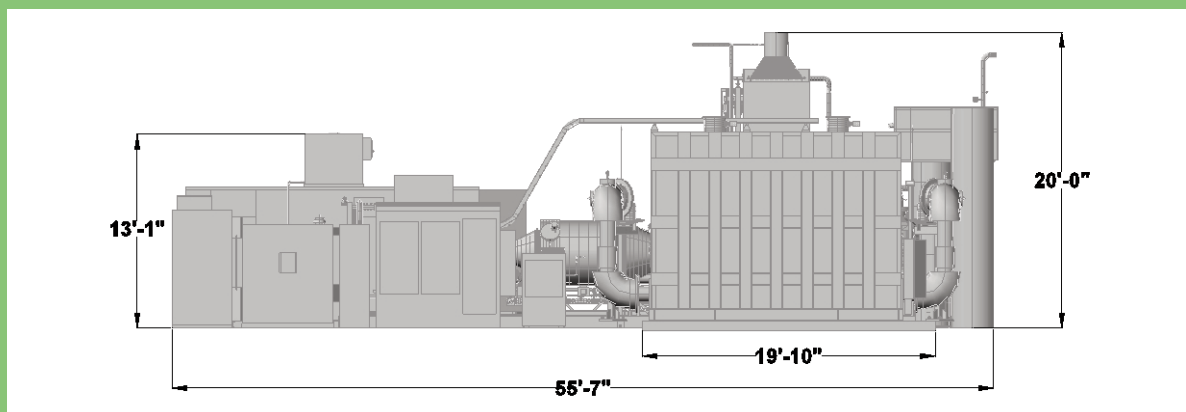

Experience & Capabilities

Direct FuelCell® power plants are generating ultra-clean, efficient and reliable power at more than 50 locations worldwide. With over 180 megawatts of power generation capacity installed or in backlog, FuelCell Energy is a global leader in providing ultra-clean baseload distributed generation to utilities, industrial operations, universities, municipal water treatment facilities, government installations and other customers around the world. The Company's power plants have generated more than one billion kilowatt hours of ultra-clean power using a variety of fuels including renewable biogas from wastewater treatment and food processing, as well as clean natural gas. For more information please visit our website at www.fuelcellenergy.com

This brochure provides a general overview of FuelCell Energy products and services. This brochure is provided for informational purposes only. Warranties for FuelCell Energy products and services are provided only by individual sales and service contracts, and not by this brochure. This brochure is not an offer to sell any FuelCell Energy products and services. Contact FuelCell Energy for detailed product information suitable for your specific application. FuelCell Energy reserves the right to modify its products, services, and related information at any time without prior notice.

FuelCell Energy's fleet of Direct FuelCell power plants are certified to or comply with a variety of commercial and industrial standards: ANSI/CSA America FC-1, UL 1741, CARB 2007, OSHA 29 CFR Part 1910, IEEE 1547, NFPA 70, NFPA 853, and California Rule 21.

FuelCell Energy with the corresponding logo is a registered trademark of FuelCell Energy, Inc. "Direct FuelCell," "DFC" and "DFC/T" are registered trademarks of FuelCell Energy, Inc. © FuelCell Energy, Inc. 2012. All rights reserved.

FuelCell Energy, Inc.
3 Great Pasture Road
Danbury, CT 06813-1305
203 825-6000
www.fuelcellenergy.com



FuelCell Energy
Ultra-Clean, Efficient, Reliable Power